

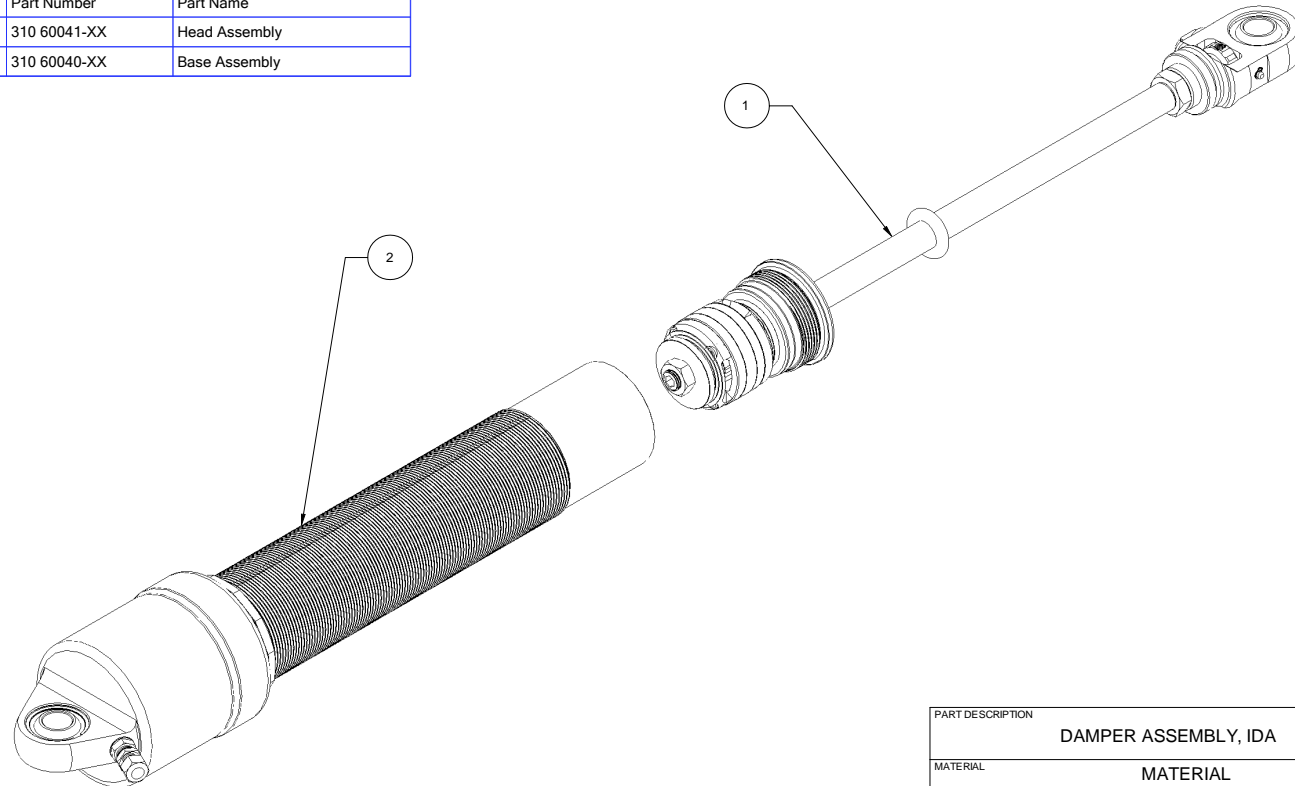

REVISIONS				
ZONE	REV	DESCRIPTION	DATE	APPROVED
	A	RELEASED	19-MAY-2009	

Item Number	Quantity	Part Number	Part Name
1	1	310 60041-XX	Head Assembly
2	1	310 60040-XX	Base Assembly



PART DESCRIPTION			
DAMPER ASSEMBLY, IDA			
MATERIAL			
MATERIAL			
DRAWN BY		APPROVAL	
MLZ		APPROVER	
SIZE	FSCM NO.	DWG NO.	REV
B		310 604XX	A
SCALE		SHEET	
1" = 2"			

THIS DRAWING, INFORMATION, AND TECHNICAL DATA CONTAINED WITHIN ARE THE EXCLUSIVE PROPERTY OF INTEGRA RACING SHOCKS AND SHALL BE RETURNED UPON REQUEST. THIS DRAWING IS NOT TO BE REPRODUCED IN WHOLE OR IN PART, NOR SHALL ANY INFORMATION OR TECHNICAL DATA BE SUPPLIED IN ANY FORM TO ANYONE ELSE WITHOUT THE EXPRESS WRITTEN CONSENT OF INTEGRA RACING SHOCKS

BREAK EDGES .010  $\pm$  .0005" X 45°; FILLET RADIUS 0.010"  $\pm$  0.0005"  
 TOLERANCES (UNLESS OTHERWISE SPECIFIED):  
 .XX  $\pm$  .01", .XXX  $\pm$  .003", ANG  $\pm$  0.5°  
 ALL SURFACE FINISHES TO BE Ra 64 OR BETTER UNLESS OTHERWISE SPECIFIED.

310 604XX\_DAMPER ASSEMBLY, IDA